

COMBI BOILERS

23 – 60 kW 78,500 – 205,000 BTU/h

NORTH AMERICA

HARGASSNER
BIOMASS HEATING TECHNOLOGY



40
YEARS

SUSTAINABILITY | EXPERTISE | INNOVATION | FAMILY-OWNED



hargassner.com

Table of contents

- 4 Good reasons for heating using pellets and wood logs
- 6 Overview of all Combi boilers
- 8 The combinable boilers
- 10 Smart-HV 23 + Smart-PK 32
- 12 Smart-HV 23 + Nano-PK32
- 14 Neo-HV 60 + Smart-PK 32
- 16 Neo-HV 60 + Nano-PK 32
- 18 Boiler operation and touch display
- 19 Smart home and control unit
- 20 Storage room solutions (week hopper, bag silo & underground tank and fuel extraction systems
- 22 Accumulator systems
- 23 Heating accessories
- 24 Technical data



The world of biomass

"The delivery of pellets or wood chips **smells like Christmas**", was the statement of one of our satisfied clients. It's the smell of wood, made of residual wood from domestic forests and wood from local mills. The carbon that is released by pellet or Wood chip boilers is already in the active carbon cycle in form of trees. It is moving in this cycle and not producing new carbon that is emitted to the atmosphere compared to boilers that use fossil fuel.

Treating nature with care and caution is part of our philosophy. Therefore, it is even more important for our future generations to choose the correct heating system and the right fuel. **From an ecological and economic perspective, heating with wood is the most natural raw material for this purpose.**

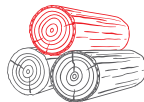

Biomass

Canada produces actually 4 Mio tonnes of biomass per year and is exporting 3,8 Mio tonnes to the northern part of Europe or Japan.



Reduce your carbon footprint

The carbon that is released by biomass boilers is already in the active carbon cycle in form of trees. It is moving in this cycle and not producing new carbon that is emitted to the atmosphere.



Local economic impacts

Heating with biomass has other positiv impacts like: New jobs or a better supplying of the local foresters.



Save money

Lower heating costs than oil or gas. Additionally you can get financial support through subsidies from your local government.



40 YEARS

4 decades of Hargassner = 4 decades of future heating technology

Hargassner. Since 1984, as a pioneer in automated biomass heating systems, we have endeavoured to stand by our customers as a reliable partner – with trustworthiness from Innviertel. We have now grown into an internationally successful company with a pronounced spirit of innovation.

- ✓ **40 years of experience**
- ✓ **185.000 customers** worldwide
- ✓ **75.000 m² company floor space**
- ✓ **1.200 employees**
at several locations
- ✓ **Export to 43 countries**
- ✓ **40 years of international awards**



Managing directors (left to right)
Markus & Anton jr. Hargassner



Heating with wood log and pellets

Advantages

- ✓ **Lower costs than oil or gas**
- ✓ **Crisis-resistant**, because locally sourced
- ✓ **Short transportation**
- ✓ **Value creation process remains in the region**
- ✓ **Efficient and energy saving**
- ✓ **High calorific value**

Environmentally friendly. Wood fuels are CO₂ neutral. In general, the cleaner combustion results in a CO₂ reduction compared to heating oil.

Domestic economy. The use offers a future-proof market for local companies and secure jobs in the region.

Efficient. Low fuel costs and highly efficient boiler technology makes a wood log combination attractive not only for forest owners.

Independent. There is a high degree of independence due to the supply from domestic forests. Control over the production process is entirely domestic.



Wood log facts

1/2 metre: EN ISO 17225-5:2014, class A1-B, L50
1 metre: EN ISO 17225-5: 2014 class A1-B, L100
Size: Ø 10 cm on average for 1/2 m
Water content: < 20%
Calorific value: 4.4 kWh/kg

Pellets facts



Standards: EN ISO 17225-2, ÖNORM 7135, class A1
Density: 650 kg/m³
Ø / length: 6 mm / approx. 5 – 40 mm
Water content: w < 10%
Calorific value: 4.8 – 4.9 kWh/kg



The best alternatives to oil and gas – annual heating cost savings*

Comparing the costs of individual fuels down into cents per kilowatt hour reveals an astonishing picture:

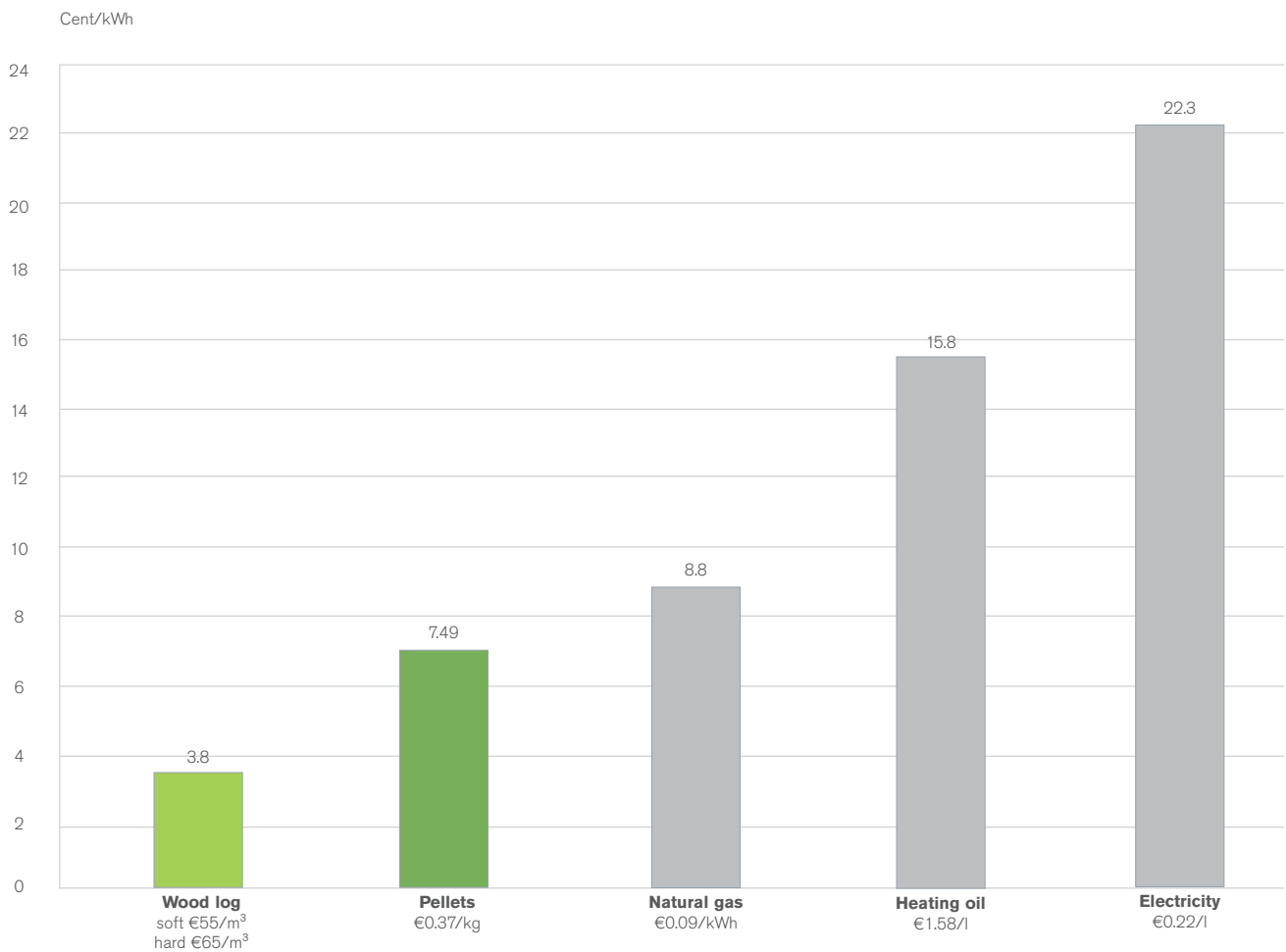

* Last updated 06/2022 Sources: Gas: e-control, heating oil: IWO, pellets: Genol and proPellets Austria.

The variety of our combi boilers

SMART HV SMART PK

23 kW 78,500 BTU/h +
32 kW 109,000 BTU/h

- Wood log/pellet
combi boiler
with lowest
purchase costs

For details, see p. 10



SMART HV NANO PK

23 kW 78,500 BTU/h +
32 kW 109,000 BTU/h

- Suitable for the
pellet boiler operator
with occasional
wood log operation

For details, see p. 12



Perfect heating

Hargassner has been a pioneer in biomass heating technology for many years, giving it an advantage in expertise which has already resulted in enormous technological advances in the combination of wood log and pellet boilers. The best ideas and solutions in terms of both the design and the control strategy produce the best results. High levels of comfort, best quality and long lifetime characterise the Hargassner brand and its products.



NEO HV SMART PK

60 kW 205,000 BTU/h +
32 kW 109,000 BTU/h

- Suitable for the wood log boiler operator with occasional pellet operation

For details, see p. 14



NEO HV NANO PK

60 kW 205,000 BTU/h +
32 kW 109,000 BTU/h

- Wood log heating with full pellet comfort for premium customers

For details, see p. 16



- ✓ **Highest controllability** and **maximum efficiency**
- ✓ **Fuel supply security** for the future
- ✓ **Two separate, efficient heat exchanger systems** for just one chimney
- ✓ **Fully automatic changeover**





Combinable **wood log boilers**

NEO HV

60 kW 205,000 BTU/h

All the technical details have been optimised for the Neo-HV, which has made operating and maintaining the boiler considerably easier. A separate premium package increases the Hargassner operating comfort to a maximum.*

- ✓ **Filling chamber size for ½ m logs**
- ✓ **State-of-the-art combustion control**
- ✓ Automatic **boiler cleaning device**
- ✓ **Touch display** for convenient adjustment
- ✓ Standard **filling chamber lighting**



SMART HV

23 kW 78,500 BTU/h

The Smart-HV impresses with its compact size, its functionality and of course its excellent price-performance ratio. The ingenious gasification technology comes from its exclusive brother – the Neo-HV.*

- ✓ **Filling chamber size for ½ m logs**
- ✓ **Sophisticated wood gasification technology**
- ✓ **Smoke-free refilling**
- ✓ **Easy filling**





OTHER COMBINATION POSSIBILITIES!

Every Hargassner boiler can be combined with a second system. Wood chip or larger system combinations are also possible. If you are interested, your Hargassner commissioning engineer company will be happy to advise you on site.

Combinable **pellet boilers**

NANO PK
32 kW 109,000 BTU/h

The low-temperature boiler is equipped with the latest heating technology for economical heating requirements. The boiler series is particularly suitable for detached or semi-detached houses with minimum space such as in houses without a cellar.*

- ✓ **Low-temperature boiler as of 40°C**
- ✓ **Simple installation**
Maintenance openings at the front and top
- ✓ **Automatic pellet filling**
from the week hopper or pellet store
- ✓ **Integrated hydraulic modules**



SMART PK
32 kW 109,000 BTU/h

Manual filling enables sensational price-performance ratio and individual control over fuel filling. The hopper allows a continuous burning time of up to 10 days.*

- ✓ **Compact design**
- ✓ **Pellet day hopper** 174 kg
- ✓ **Easy filling** with bags of pellets





SMART HV + SMART PK

23 kW 78,500 BTU_h + 32 kW 109,000 BTU_h



This cost-efficient Hargassner solution consists of a Smart-HV wood log boiler and a Smart-PK pellet boiler that are both filled manually. The heat exchanger is also cleaned manually. If the wood log boiler is empty, the system will automatically switch to pellets. This combi option can run for up to ten days without being refilled.





- ✓ **Cost-effective**
- ✓ **Automatic switch** to pellets
- ✓ **Simple, manual filling** of both boilers
- ✓ **Up to 10 days of heating** without refilling



Smart-HV 17 - 23 + Smart-PK 17 - 32

Application areas

-  Detached houses
-  Semi-detached houses
-  For frugal customers with low purchase costs

-  HxWxD = 1,200x600x900 mm (Smart-HV 17 - 23)
-  HxWxD = 1,520x1,080x650 mm (Smart-PK 17 - 32)
-  Energy efficiency class **A+**
-  Efficiency of up to 96 %
-  5-year warranty

Combination system with perfect price-performance ratio

Smart-HV 23 + Smart-PK 32

- 1 Large filling door
- 2 Filling chamber for ½ m logs (up to 53 cm)
- 3 Combustion chamber lining – prevents tar formation
- 4 Primary air motor
- 5 Secondary air motor
- 6 High-quality, massive refractory-lined combustion chamber
- 7 High-temperature burnout zone
- 8 Ash separation zone
- 9 Lambda sensor
- 10 Turbulators
- 11 Heat exchanger
- 12 Manual boiler cleaning device
- 13 Exhaust fan
- 14 Top smoulder gas ventilation
- 15 Optional back-end protection
- 16 Cooling coil for thermal safety circuit
- 17 Cleaning door
- 18 Ash pan

- 1 Fully refractory-lined combustion chamber
- 2 Sliding grate
- 3 Secondary air stream with inlet openings
- 4 Primary air
- 5 Ash pan
- 6 Automatic ignition with 300 W
- 7 Stoker auger
- 8 Heat exchanger
- 9 Turbulators with manual heat boiler cleaning system
- 10 Exhaust fan
- 11 Pellet day hopper
- 12 Metering rotary valve
- 13 Lambda sensor
- 14 Air connection AIO / ADO
- 15 Fill level indicator

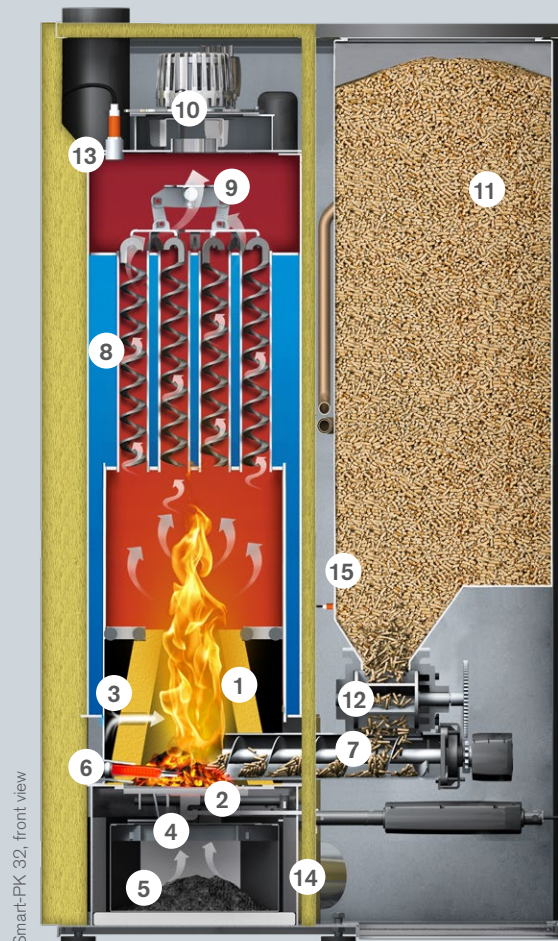
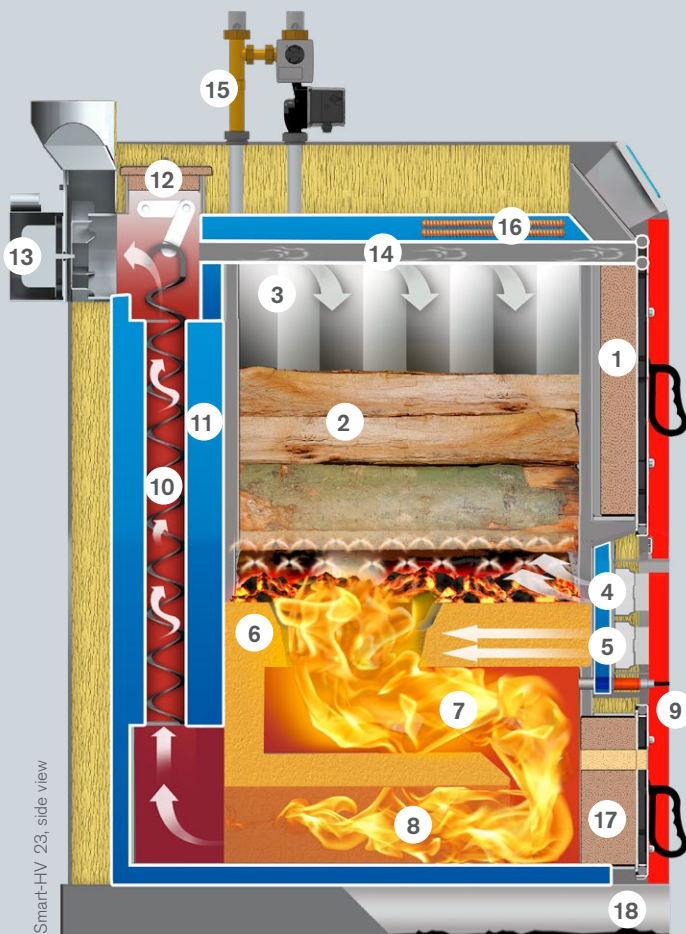



SMART HV + NANO PK



23 kW 78,500 BTU_h + 32 kW 109,000 BTU_h

This option consisting of the Nano-PK pellet boiler with an automatic heat exchanger cleaning system and a fuel extraction system in combined with a Smart-HV wood log boiler is distinguished by its small, compact design. The pellets are automatically suctioned out of their storage room and into the hopper. This combi option can run completely automatically over an extended period of time.

- ✓ **Automatic heat exchanger cleaning**
in the pellet boiler
- ✓ Longer **automatic operating duration**
- ✓ Pellets are automatically suctioned into the hopper



Application areas

-  Detached houses
-  Semi-detached houses
-  For pellet boilers with occasional wood log operation

- ⊕ — HxWxD = 1,200x600x900 mm (Smart-HV 17-23)
- ⊕ — HxWxD = 1,350x780x580 mm (Nano-PK 6-15)
- ⊕ — Energy efficiency class **A+**
- ⊕ — Efficiency of up to 96 %
- ⊕ — 5-year warranty

The combi system for pellet boilers

Smart-HV 23 + Nano-PK 32

- 1 Large filling door
- 2 Filling chamber for 1/2 m logs (up to 53 cm)
- 3 Combustion chamber lining – prevents tar formation
- 4 Primary air motor
- 5 Secondary air motor
- 6 High-quality, massive refractory-lined combustion chamber
- 7 High-temperature burnout zone
- 8 Ash separation zone
- 9 Lambda sensor
- 10 Turbulators
- 11 Heat exchanger
- 12 Manual boiler cleaning device
- 13 Exhaust fan
- 14 Top smoulder gas ventilation
- 15 Optional back-end protection
- 16 Cooling coil for thermal safety circuit
- 17 Cleaning door
- 18 Ash pan

- 1 Fully refractory-lined combustion chamber
- 2 Sliding grate
- 3 Secondary air stream with inlet openings
- 4 Primary air
- 5 Ash pan
- 6 Automatic ignition with 300 W
- 7 Stoker auger
- 8 Heat exchanger
- 9 Turbulators with autom. boiler cleaning system
- 10 Exhaust fan
- 11 Pellet vacuum turbine
- 12 Pellet day hopper
- 13 Metering double rotary valve
- 14 Lambda sensor
- 15 Air connection AIO / ADO
- 16 Fill level indicator

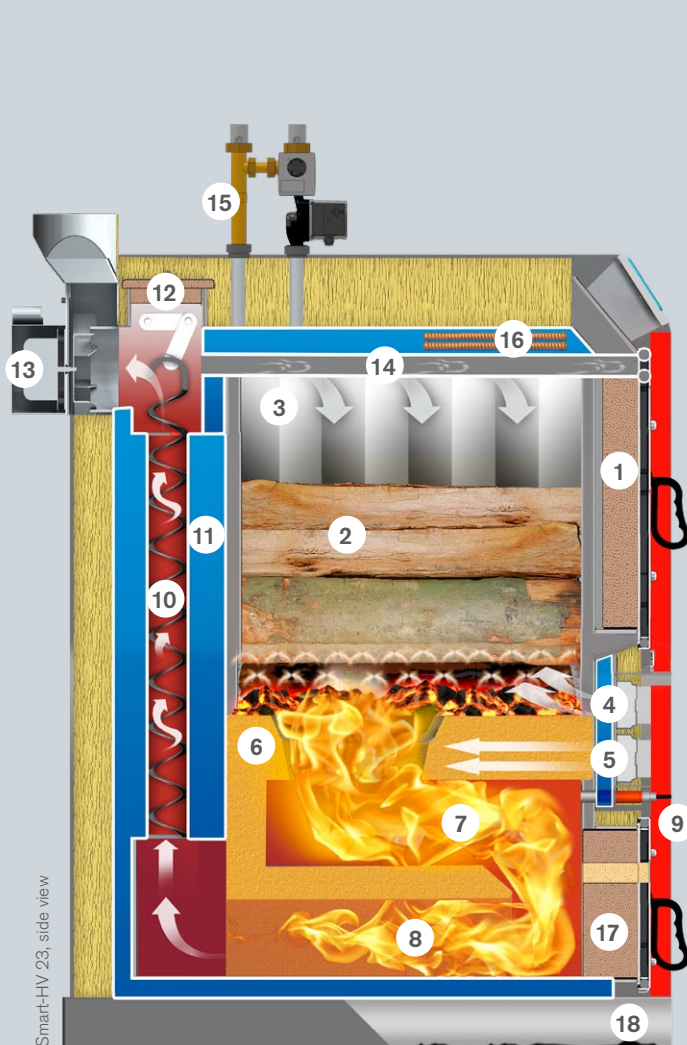

Smart-HV 23, side view

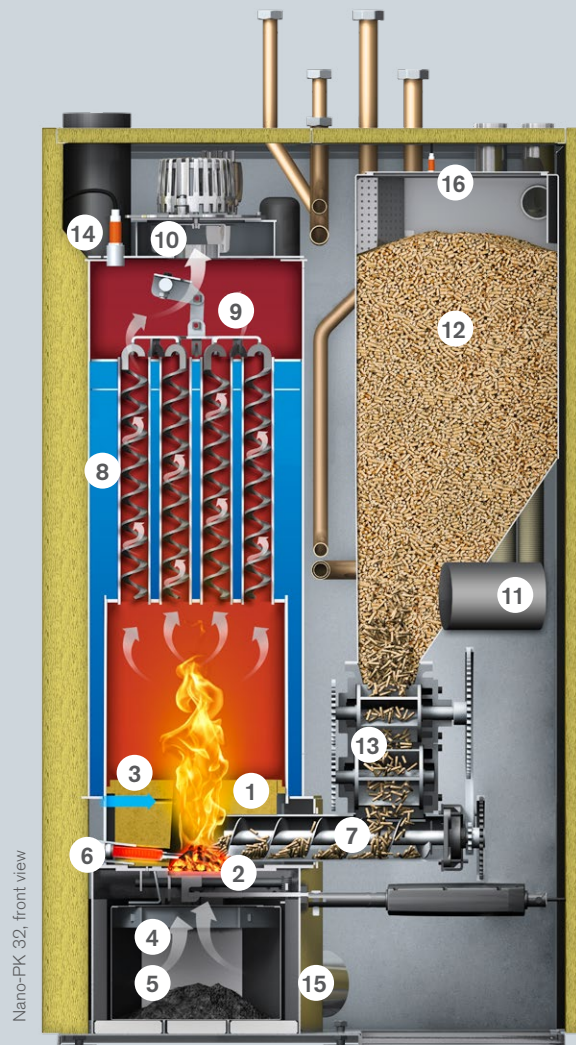

Nano-PK 32, front view



NEO HV + SMART PK

60 kW 205,000 BTU/h + 32 kW 109,000 BTU/h



This combination consisting of the automatic Neo-HV wood log boiler with a large filling chamber and the Smart-PK pellet boiler with manual filling and a long filling interval of up to a week guarantees maximum heating convenience. The wood log boiler is ignited automatically when the accumulator can no longer cover the heat demand. If the wood log boiler is empty, the system will automatically switch to pellets. This combi option can run for up to ten days without being refilled.





- ✓ **Automatic wood log operation**
- ✓ **Automatic switch** to pellets
- ✓ 10 days of heating without refilling



Neo-HV 20-30 + Smart-PK 17-32

Application areas

-  Detached houses
-  Semi-detached houses
-  For wood log boilers with occasional pellet operation

-  HxWxD = 1,665 x 660 x 1,310 mm (Neo-HV 20-30)
-  HxWxD = 1,520 x 1080 x 650 mm (Smart-PK 17-32)
-  Energy efficiency class **A+**
-  Efficiency of up to 96 %
-  5-year warranty

The combi boiler for wood log boilers

Neo-HV 60 + Smart-PK 32

- 1 Large filling door
- 2 Large filling chamber for ½ m logs (up to 60 cm)
- 3 Combustion chamber lining – prevents tar formation
- 4 Heat-up door with automatic ignition (optional)
- 5 Primary air motor
- 6 Secondary air motor
- 7 High-quality, massive refractory-lined combustion chamber
- 8 High-temperature burnout zone
- 9 Ash separation zone
- 10 Lambda sensor
- 11 Turbulators
- 12 Heat exchanger
- 13 Autom. boiler cleaning system
- 14 Exhaust fan
- 15 Top smoulder gas ventilation
- 16 Optional back-end protection
- 17 Cooling coil for thermal safety circuit
- 18 Cleaning door
- 19 Ash pan
- 20 Standard filling chamber lighting

- 1 Fully refractory-lined combustion chamber
- 2 Sliding grate
- 3 Secondary air stream with inlet openings
- 4 Primary air
- 5 Ash pan
- 6 Automatic ignition with 300 W
- 7 Stoker auger
- 8 Heat exchanger
- 9 Turbulators with manual heat boiler cleaning system
- 10 Exhaust fan
- 11 Pellet day hopper
- 12 Metering rotary valve
- 13 Lambda sensor
- 14 Air connection AIO / ADO
- 15 Fill level indicator

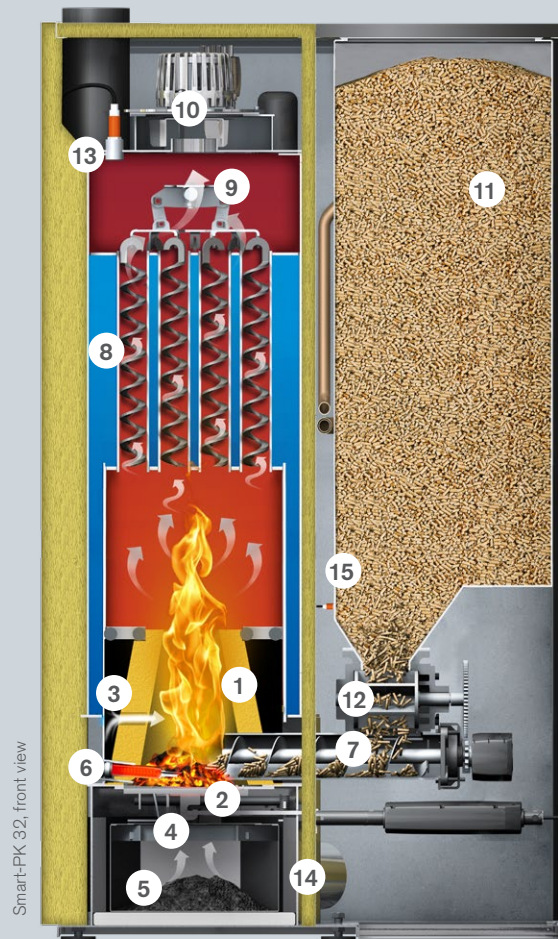
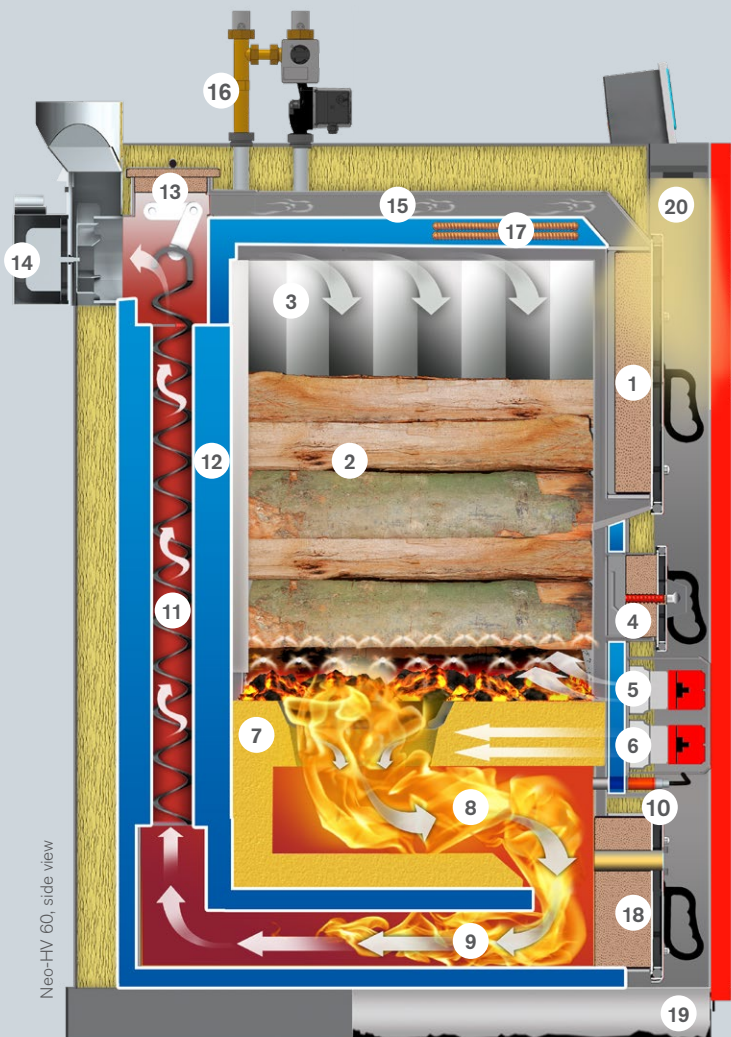





NEO HV + NANO PK

60 kW 205,000 BTU_h + 32 kW 109,000 BTU_h

This combi option is impressive because it consists of the Neo-HV wood log boiler boasting a large filling chamber and the Nano-PK pellet boiler with an automatic heat exchanger cleaning system and an innovative fuel extraction system. The wood log boiler is ignited automatically when the accumulator can no longer cover the heat demand. If the wood log boiler has not been filled, the system will switch to the pellet boiler. The pellets are suctioned out of their storage room and into the hopper.





- ✓ **Autom. boiler cleaning system**
- ✓ Optional **automatic ignition**
- ✓ **Touchpad operation**
- ✓ **Fully refractory-lined high-performance combustion chamber**
for optimum post-combustion
- ✓ **One control unit for both boilers**

Application areas

-  Detached houses
-  Semi-detached houses
-  Fully automatic combi boiler for premium customers



Neo-HV 20-60 + Nano-PK 6-15

-  HxWxD = 1,665 x 660 x 1,310 mm (Neo-HV 20-30)
-  HxWxD = 1,350 x 780 x 580 mm (Nano-PK 6-15)
-  Energy efficiency class **A+**
-  Efficiency of up to 96 %
-  5-year warranty

The combi boiler for premium customers

Neo-HV 60 + Nano-PK 32

- 1 Large filling door
- 2 Large filling chamber for ½ m logs (up to 60 cm)
- 3 Combustion chamber lining – prevents tar formation
- 4 Heat-up door with automatic ignition (optional)
- 5 Primary air motor
- 6 Secondary air motor
- 7 High-quality, massive refractory-lined combustion chamber
- 8 High-temperature burnout zone
- 9 Ash separation zone
- 10 Lambda sensor
- 11 Turbulators
- 12 Heat exchanger
- 13 Autom. boiler cleaning system
- 14 Exhaust fan
- 15 Top smoulder gas ventilation
- 16 Optional back-end protection
- 17 Cooling coil for thermal safety circuit
- 18 Cleaning door
- 19 Ash pan
- 20 Standard filling chamber lighting

- 1 Fully refractory-lined combustion chamber
- 2 Sliding grate
- 3 Secondary air stream with inlet openings
- 4 Primary air
- 5 Ash pan
- 6 Automatic ignition with 300W
- 7 Stoker auger
- 8 Heat exchanger
- 9 Turbulators with autom. boiler cleaning system
- 10 Exhaust fan
- 11 Pellet vacuum turbine
- 12 Pellet day hopper
- 13 Metering double rotary valve
- 14 Lambda sensor
- 15 Air connection AIO / ADO
- 16 Fill level indicator

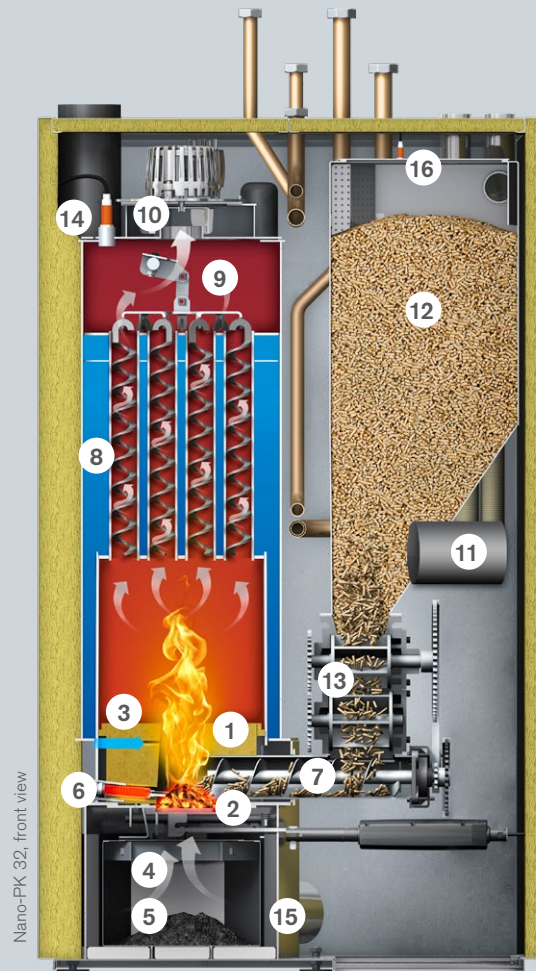
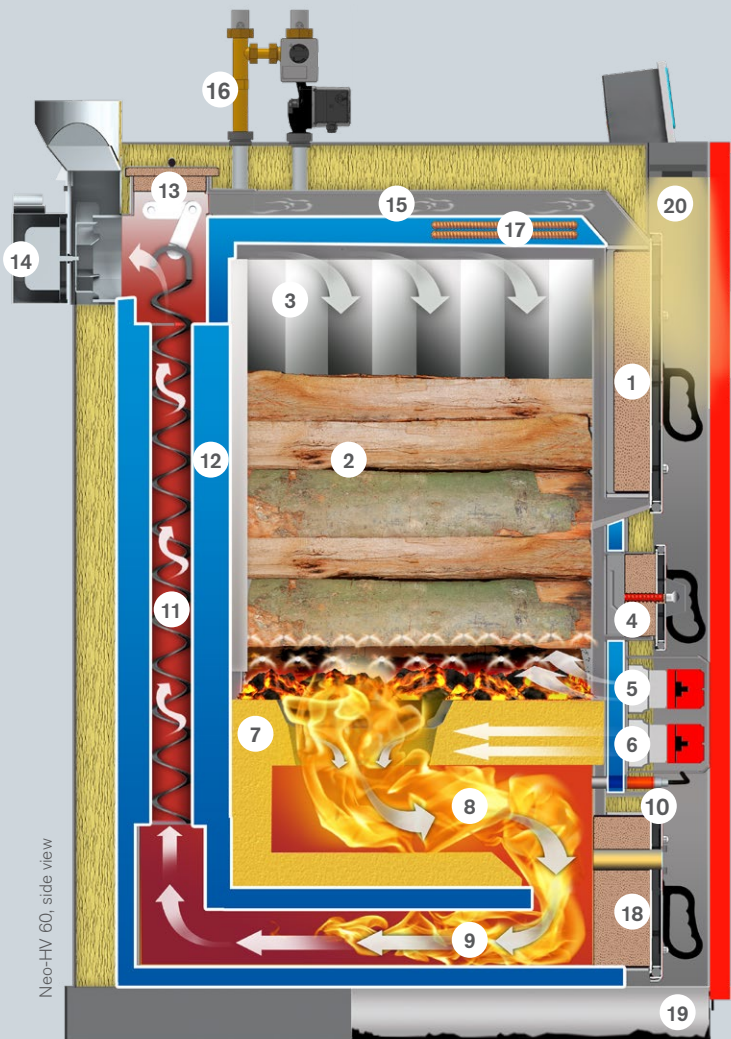



Hargassner has control programmes for all boiler series; these programmes are all clearly arranged and easy to use. They provide a convenient way to control heat circuits and hot water.

Maximum operating convenience



Hargassner Lambda Touchtronic

The Hargassner Lambda Touchtronic is distinguished by an exceptionally simple design and the fact that the Nano-PK and Neo-HV boiler series are very easy to operate. It will control your entire heating system, from the transport of the fuel to the combustion to the heat circuits and hot water tanks. It is guided by weather conditions, so recognises changes in conditions as soon as they occur and is able to seamlessly adjust the boiler's output accordingly. As a result, the boiler is always running in the optimum output range, enabling you, the customer, to save both fuel and unnecessary costs.

Effortless operation with the Smart-Line

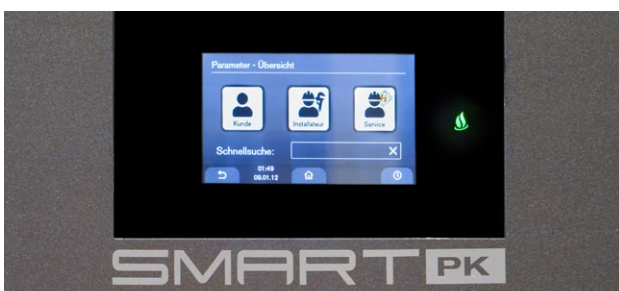

Hargassner Smart-Touch

The Smart boiler series is equipped with Hargassner's new Smart-Touch control unit. It is complemented by extra capacity for up to three mixed heat circuits and hot-water production, provided in the form of an additional board or a heat circuit module. This makes the new Smart-Touch control a perfectly tailored solution for the entire boiler system.

Remote control via phone or tablet



App for mobile heating control

The Hargassner app allows you to control the heating quickly and on the move and view information worldwide around the clock. The app immediately sends important information to the mobile end device via email or push message. This way, you know the status of the boiler at all times. (Requirements: Internet Gateway, smartphone with Android or iOS)



Awarded the App-Award 2022

The Hargassner app picked up an excellent first place in the heating control app category in 2022. The "Deutsche Gesellschaft für Verbraucherstudien" (German company for consumer studies) investigated customer satisfaction and which apps could really inspire their users. Hargassner came out on top among 28 apps and thus received the App Award 2022.



Internet Gateway

Required for app and WEB service. The Internet Gateway will establish a secure TLS-encrypted connection between your Hargassner boiler's control unit and the internet router. This way, you can safely access the heating system with your mobile device.



Convenient remote controls

You want to change a setting on your boiler or see the current status – without going to your boiler room? No problem! The practical remote controls leave no operating wishes unfulfilled. They are simple, intuitive and boast a design that's perfectly tailored to your needs! Details of our analogue and digital (touch) remote controls can be found on our website hargassner.com

Control accessories for every need

Hargassner offers comprehensive accessory options. The Hargassner standard control covers the majority of the requirements in a modern house. However, if further heat circuits, solar panels, etc. are to be connected, additional boards and remote controls are available. The right solution for every requirement: for more information, visit our homepage or contact your Hargassner installation company.



Smart home connections

"Smart home" is an innovative way of controlling the management of energy in your home according to your needs. Hargassner has a connection ready for the most common home automation systems (Loxone, KNX, Mod-Bus, etc.). The benefits are clear. You save energy and costs and enjoy comfort and safety at the same time.



STORAGE ROOM SOLUTIONS

Week storages – small pellet stores for indoor use

There are two different week storages. The standard hopper has an optimal filling height and a large filling space; therefore, it is very convenient to fill with bags. The second hopper is specially developed for the combination with the Nano-PK pellet boiler and impresses with its tall, narrow design.

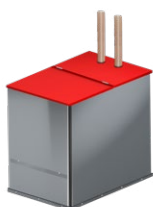

Weekly storage

- 770 l filling volume
- for 500 kg pellets
- 770 x 1,150 x 1,090 mm
- Filling with bags



Nano-PK weekly storage

- 340 l filling volume
- for 220 kg pellets
- 580 x 580 x 1,220 mm
- Filling with bags

Bag silo – complete storage room system

Hargassner also offers a range of different types and sizes of bag silos for pellets – from 2 to 8.2 t storage capacity. You choose between a fixed (GWTS) or "growing" (GWT-MAX) solution.

- ✓ **Minimum space requirements**
- ✓ **Quick and easy to install**
- ✓ **Dust-tight, durable and antistatic filter fabric**
- ✓ **Protected against condensation**



Underground tanks – for simply more space

Hargassner underground tanks (PET) are ready-made spherical storage rooms for underground use. By simply sinking them into the garden or driveway, they create open spaces in the house.

- ✓ **Creates an external pellet store**
- ✓ Ideal for **renovation projects** & new buildings
- ✓ **Concrete-free installation**
- ✓ **Can also be driven over**
- ✓ **Discreet cover** visible from above



Point extraction – ideal for all room shapes

No matter whether small, square or complexly shaped storage rooms, a point extraction system (RAPS) works everywhere.

One or more flexible extraction points suck the pellets out of the storage room. For this purpose, sloping floors made of wooden boards with a 35 degree slope are installed beforehand. They guarantee good emptying towards the extraction points. If an area of the storage room is empty, the system switches manually or automatically to another extraction point. The auto changeover units (AUP) are available in two-, three-, four- or eight-fold versions and can even be used in small rooms without a sloping floor.

- ✓ **Ideal for small to complex rooms**
- ✓ **Bridges distances up to 20 m**
between storage & boiler room
- ✓ **Makes optimal use of the room volume**
- ✓ **AUP saves costs**
- ✓ **Maximum comfort thanks to automatic changeover (AUP)**



Fuel extraction auger – reliable for any size

Thanks to the combinations of suction system and extraction auger (RAS), every pellet finds its way safely to the boiler.

Fuel extraction augers show their robust strength in long storage rooms with space for an extraction motor. With the transport auger, the pellet quantity can be finely adjusted during transport. The suction system is completely emptied when it is switched off, thus avoiding overfilling jams. Sloping floors help with the optimal feed of pellets to the auger. It is even possible to combine two extraction augers, in which case an automatic changeover unit (AUP) is used to switch between them.

- ✓ **Ideal for long rooms**
- ✓ **Bridges distances up to 30 m**
between storage & boiler room
- ✓ **Robust and reliable**
- ✓ **Optimal use of the room volume**
- ✓ **Auger lengths of 1.5 – 8 m**





Accumulator systems for storing heat

Storing heat and excess energy from the heating water in the accumulator saves money. Depending on the model, they also heat the fresh water. The Hargassner storage systems are optimised for the key requirements of heat storage and hot water preparation.

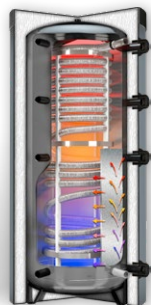

Universal heat storage tank – layered accumulators

Layered accumulators of the types SP, HSP, SP-FWS and their solar variants are all perfectly tuned to Hargassner heating systems. Your Hargassner heating company will plan the right version for you. The addition of a freshwater station or a heat circuit group to the models is provided. The "spread sheet" guarantees optimum temperature stratification and particularly efficient energy utilisation. This saves heating costs in the long run.

- ✓ **Optimised energy utilisation** in the accumulator
- ✓ **Insulation and hard casing**
- ✓ Suitable for **combination with solar**
- ✓ **Easy and flexible installation**, can be switched in parallel
- ✓ **Special storage tanks of up to 150,000 l**
- ✓ **Very little space required**

Hargassner is the full-range supplier for biomass central heating systems.

Hydraulic components, accessories of all kinds are available extensively and in individual designs for all requirements. Precise coordination of the entire heating solution guarantees optimal cooperation of each individual component with each other. Additional information can be found in further product brochures or on hargassner.com (also as download).



Find out more about our heating accessories at hargassner.com

Various heating components



Substation, heat meter, freshwater station & heat circuit groups

Expandable hydraulic components for heat circuit groups, freshwater preparation, etc. are adapted to the Hargassner boilers. Their control functions are taken over exactly by the Hargassner control system on the boiler.

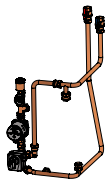

Integrated hydraulic modules

A wide variety of design is available for the hydraulic modules of the Nano-PK and Smart-PK pellet boilers. All pumps, connections and piping are easily accessible and run upwards.



Premium solar panels

As an ideal complement to biomass heating systems, Hargassner offers high-quality solar panels for the preparation of heating and hot water. They are available as flat-plate panels with high performance and a long lifetime, and they are available in reinforced versions for regions with high snow loads. The Hargassner Group also markets vacuum flat-plate panels globally.



Back end protection

This provides automatic back-end protection for Hargassner wood log boilers while simultaneously loading an accumulator tank. A fully insulated back-end protection group that includes a return mixer and highly efficient accumulator loading pump can be installed quickly and easily and reduces installation time and costs.



Combi flue pipe set

The high-quality flue pipe sets in various diameters made of stainless steel integrate all the necessary components such as bows, pipes, boiler collars, seals and clamp rings. Hargassner offers a suitable flue pipe set for each combi version, with which both boilers can be connected to one chimney.



OekoTube-Inside

The OekoTube-Inside is an electrostatic micro-dust filter recognised by BAFA (Germany's Federal Office for Economic Affairs and Export Control) as an approved measure for reducing micro-dust levels. The filter is suitable for wood log & pellet boilers up to 60 kW.

TECHNICAL DATA

**Smart-HV 23 &
Smart-PK 32**

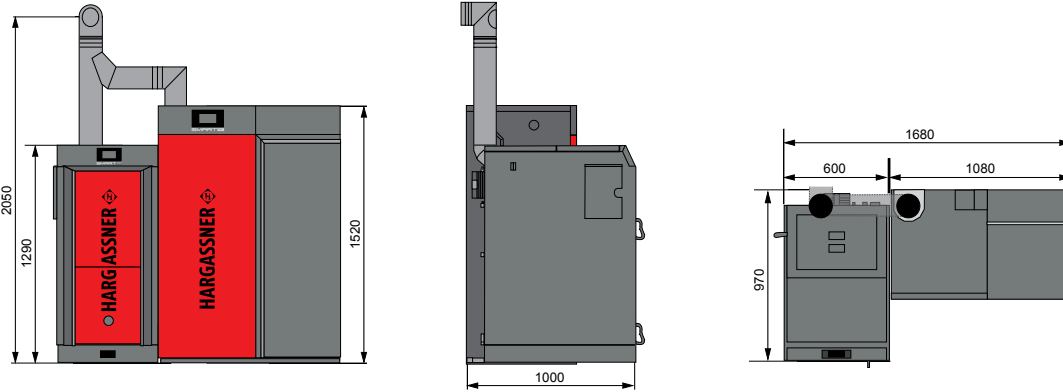

**Smart-HV 23 &
Nano-PK 32**

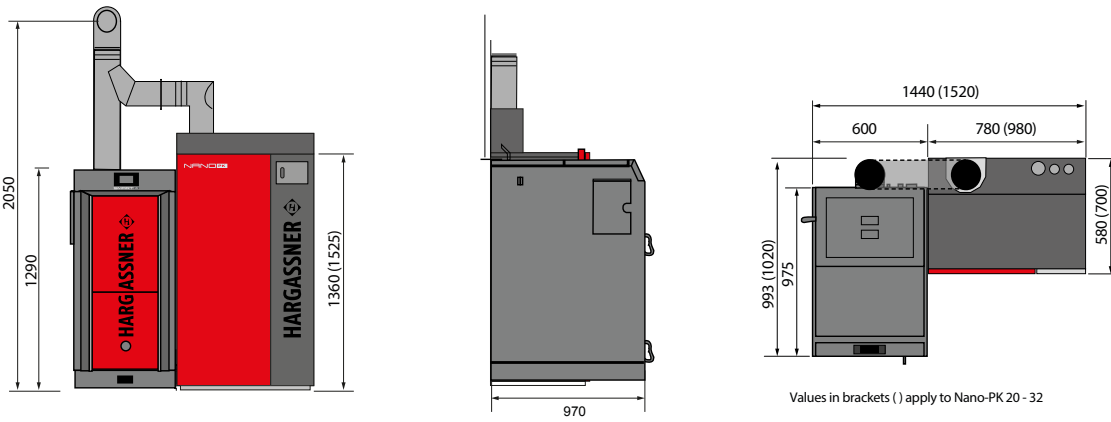

Values in brackets () apply to Nano-PK 20 - 32

**Neo-HV 60 &
Smart-PK 32**

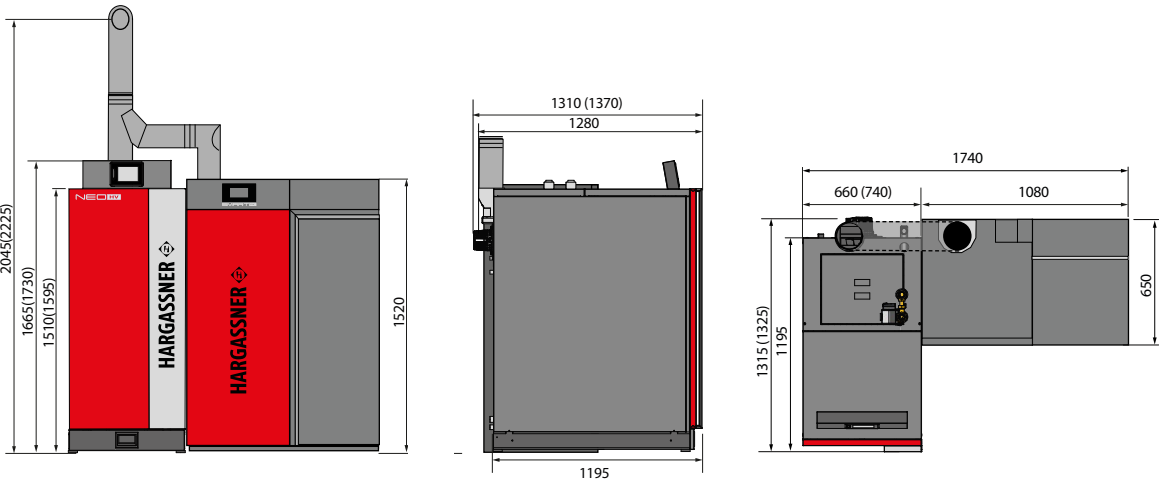

**Neo-HV 60 &
Nano-PK 32**

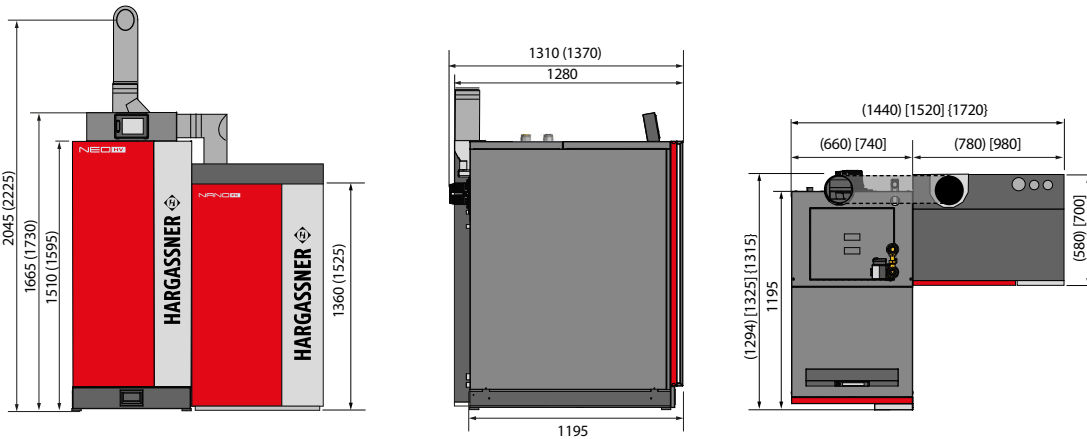

Values apply to Neo-HV 20 - 30 & Nano-PK 6 - 15
Values in brackets () apply to Neo-HV 40 - 60 & Nano-PK 20 - 32

Values in brackets () apply to Neo-HV 20 - 30 & Nano-PK 6 - 15
Values in brackets [] apply to Neo-HV 20 - 30 & Nano-PK 20 - 32
Values in brackets { } apply to Neo-HV 40 - 60 & Nano-PK 20 - 32

Smart-HV 23 & Smart-PK 32		
	Unit	Smart-HV 23 & Smart-PK 32
Nominal heating output	kW/BTU	23/78,500 32/109,000
Boiler height	mm	1,200 1,520
Boiler width	mm	600 1,080
Boiler depth	mm	900 650
Transport dimensions H / B / T	mm	1,290 x 600 x 970 1,520 x 575 x 605
Flue pipe diameter	mm	130 130
Connection Flow and return	inches	6/4 5/4
Water content	l	72 42
Weight	kg	400 290
Chimney connection height to the top/rear	mm	2,050 1,530
Boiler label	Category	A+ / A+
Composite label incl. control	Category	A+ A+

Smart-HV 23 & Nano-PK 32		
	Unit	Smart-HV 23 & Nano-PK 32
Nominal heating output	kW/BTU	23/78,500 32/109,000
Boiler height	mm	1,200 1,550
Boiler width	mm	600 980
Boiler depth	mm	900 700
Transport dimensions H / B / T	mm	1,290 x 600 x 970 1,550 x 575 x 540
Flue pipe diameter	mm	130 130
Connection Flow and return	inches	6/4 5/4
Water content	l	72 42
Weight	kg	400 370
Boiler label	Category	A+ A+
Composite label incl. control	Category	A+ A+

Neo-HV 60 & Smart-PK 32		
	Unit	Neo-HV 60 & Smart-PK 32
Nominal heating output	kW/BTU	60/205,000 32/109,000
Boiler height	mm	1,730 1,520
Boiler width	mm	740 1080
Boiler depth	mm	1370 650
Transport dimensions H / B / T	mm	1,730 x 840 x 1,450 1,520 x 575 x 605
Flue pipe diameter	mm	150 130
Connection Flow and return	inches	6/4 5/4
Water content	l	166 42
Weight	kg	810 290
Boiler label	Category	A+ / A+
Composite label incl. control	Category	A+ / A+

Neo-HV 60 & Nano-PK 32		
	Unit	Neo-HV 60 & Nano-PK 32
Nominal heating output	kW/BTU	60/205,000 32/109,000
Boiler height	mm	1,730 1,525
Boiler width	mm	740 980
Boiler depth	mm	1,370 700
Transport dimensions H / B / T	mm	1,730 x 840 x 1,450 1,550 x 575 x 540
Flue pipe diameter	mm	150 130
Connection Flow and return	inches	6/4 5/4
Water content	l	166 42
Weight	kg	810 370
Min. draught	Pa	5
Boiler label	Category	A+ / A+
Composite label incl. control	Category	A+ / A+

DIFFERENT TYPES OF STORAGE ROOM

Smart-HV with Smart-PK on right, FP vert.

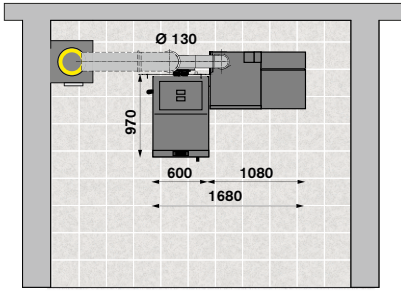

Smart-HV with Smart-PK on right, FP horiz.

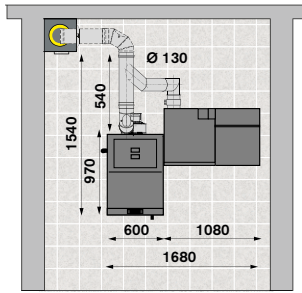

Smart-HV with Smart-PK on left, FP vert.

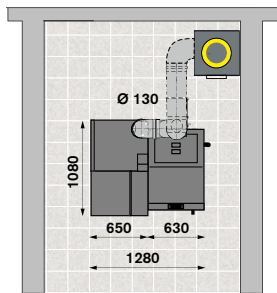

Smart-HV with Smart-PK on left, FP horiz.

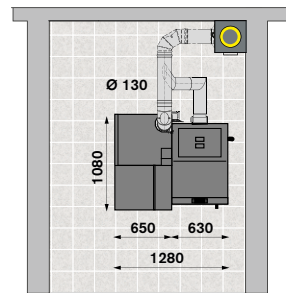

Smart-HV with Nano-PK on right, FP vert.

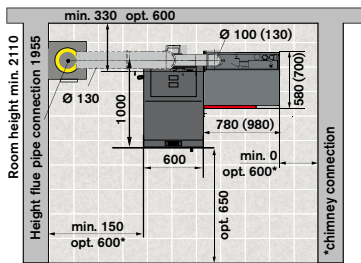

Smart-HV with Nano-PK on right, FP horiz.

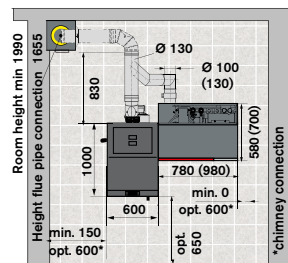

Smart-HV with Nano-PK on left, FP vert.

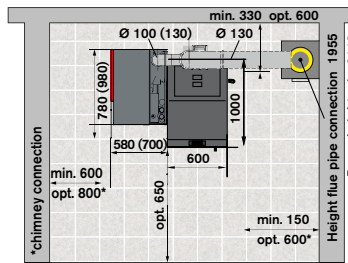

Smart-HV with Nano-PK on left, FP horiz.

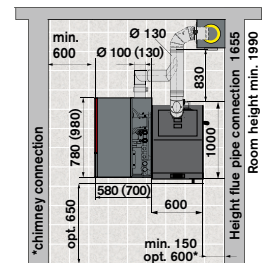

Neo-HV with Smart-PK on right, FP vert.

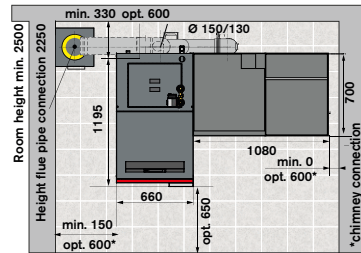

Neo-HV with Smart-PK on right, FP horiz.

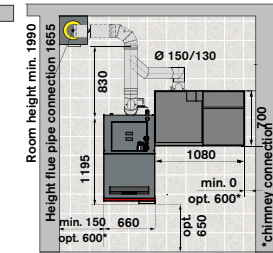

-Neo-HV with Smart-PK on left, FP vert.

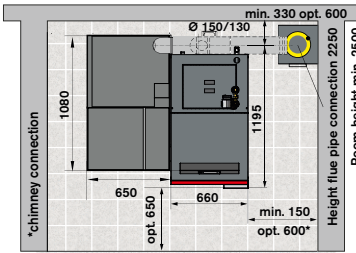

Neo-HV with Smart-PK on left, FP horiz.

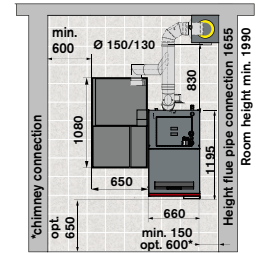

Neo-HV with Nano-PK on right, FP vert.

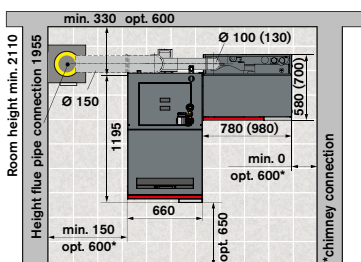

Neo-HV with Nano-PK on right, FP horiz.

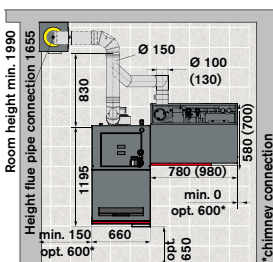

Neo-HV with Nano-PK on left, FP vert.

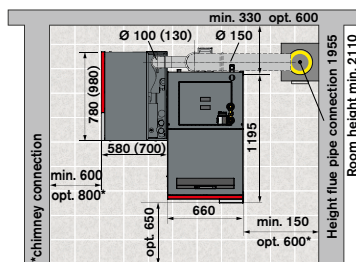

Neo-HV with Nano-PK on left, FP horiz.

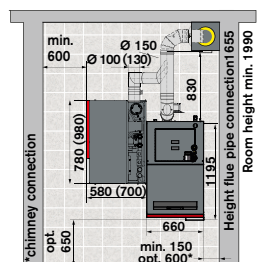

TECHNICAL DATA OF ACCESSORIES



Bag silo				
Type	Filling weight	Width	Depth	Height
GWTS 160x160	2,0 – 2,5 t	168 cm	168 cm	195 – 250 cm
GWTS 200x200	3.1 – 3.8 t	208 cm	208 cm	195 – 250 cm
GWTS 200x250	3.7 – 4.6 t	208 cm	258 cm	195 – 250 cm
GWTS 250x250	4.4 – 5.7 t	258 cm	258 cm	195 – 250 cm
GWTS 250x250 XL	6.5 t	258 cm	258 cm	270 cm
GWT-MAX 160 x 200	2.9 – 4 t	168 cm	258 cm	195 – 250 cm
GWT-MAX 160 x 250	3.6 – 5.0 t	168 cm	258 cm	195 – 250 cm
GWT-MAX 200 x 200	3.6 – 5.0 t	208 cm	208 cm	195 – 250 cm
GWT-MAX 200 x 250	4.4 – 6.0 t	208 cm	258 cm	195 – 250 cm
GWT-MAX 250 x 250	5.6 – 7.6 t	258 cm	258 cm	195 – 250 cm
GWT-MAX 250 x 250 XL	max. of 8.2 t	258 cm	258 cm	280 cm

Underground tank		
PET model	8 m ³	10 m ³
Volume	4.5 – 5.2 t	5.8 – 6.5 t
Diameter	250 cm	268 cm
Weight	280 kg	330 kg
Pit dimensions		
Diameter (min.)	3.50 m	3.75 m
Height (min.)	3.60 m	3.85 m

SP + SP SW 1+2											
	Unit	SP 500	SP 650	SP 825	SP 1000	SP 1500	SP 2000	SP 2600	SP 3000	SP 4000	SP 5000
Accumulator Volume	Litre	476	647	796	892	1445	1904	2506	2871	3887	4885
Diameter ø without insulation	mm	650	750	750	790	990	1100	1250	1250	1600	1600
Diameter ø with insulation	mm	850	950	950	990	1230	1340	1490	1490	1840	1840
Diameter ø with insulation for energy efficiency class B	mm	-	-	-	1070	1310	-	-	-	-	-
Height without insulation	mm	1630	1660	1910	2020	2090	2250	2320	2620	2250	2760
Height with insulation for energy efficiency class C	mm	1720	1750	2000	2110	2180	2340	2410	2730	2340	2895
Height with insulation for energy efficiency class B	mm	-	-	-	2150	2220	-	-	-	-	-
Tilt dimension without insulation	mm	1650	1670	1920	2030	2104	2268	2411	2690	2460	2900
Connectors 8 pcs IT	inches	6/4	6/4	6/4	6/4	6/4 (2)	6/4 (2)	10x2	10x2	10x2	10x2
Weight SP (without insulation)	kg	78	92	105	116	164	216	288	325	437	576
Weight SW1 (without insulation)	kg	102	107	130	160	-	-	-	-	-	-
Heat exchanger bottom SW1 1" IT	m ²	2	2	2	3	-	-	-	-	-	-
Weight SW2 (without insulation)	kg	-	-	154	185	252	-	-	-	-	-
Heat exchanger top/bottom SW2 1" IT	m ²	-	-	2/2	2/3	3/3	-	-	-	-	-

Max. operating pressure 3 bar, max. operating temp. 95 °C. The layered accumulators can only be supplied in conjunction with a boiler! Individual delivery on request!

HSP + HSP SW 1+2						
	Unit	HSP 500	HSP 650	HSP 825	HSP 1000	HSP 1500
Accumulator Volume	Litre	476	647	796	892	1445
Diameter ø without insulation	mm	650	750	750	790	990
Diameter ø with insulation	mm	850	950	950	990	1230
Diameter ø with insulation for energy efficiency class B	mm	930	1030	1030	1070	1310
Height without insulation	mm	1630	1660	1910	2020	2090
Height with insulation for energy efficiency class C	mm	1720	1750	2000	2110	2180
Height with insulation for energy efficiency class B	mm	1760	1790	2040	2150	2220
Tilt dimension without insulation	mm	1650	1670	1920	2030	2110
Connectors 8 pcs IT	inches	6/4	6/4	6/4	6/4	6/4
Edelstahlwellrohr – Wasserinhalt	Liter	23	23	37	37	45
Edelstahlwellrohr 5/4" AG Heizfläche	m ²	4,1	4,1	6,7	6,7	8,2
Weight HSP (without insulation)	kg	103	117	133	144	195
Weight SW1 (without insulation)	kg	119	141	157	188	-
Heat exchanger bottom SW1 1" IT	m ²	2	2	2	3	-
Weight SW2 (without insulation)	kg	-	-	182	213	284
Heat exchanger top/bottom SW2 1" IT	m ²	-	-	2/2	2/3	3/3

Max. operating pressure 3 bar, max. operating temp. 95 °C, max. drinking water operating pressure 6 bar, fire protective class B2
The layered accumulators can only be supplied in conjunction with a boiler! Individual delivery on request!



Your expert for **SUSTAINABLE HEATING**

Hargassner complete range: pellet boilers, wood chip boilers, wood log boilers, accumulator tanks, industrial boilers up to 2.5 MW, heating modules, filling augers, combined heat power (CHP), Power-Box warm-air module, heat pumps, solar collectors & hydraulic accessories

Your Hargassner partner

AUSTRIA

HARGASSNER Ges mbH
Anton Hargassner Strasse 1
A-4952 Weng
+43 77 23 52 74 - 0
office@hargassner.at
hargassner.com

NORTH AMERICA

Hargassner North America Inc.
2100-181 University Avenue
Toronto, Ontario M5H 3M7
+ 1 437 837 2300
office@hargassner-northamerica.com